

B10

Micro DC Brushless Pump



Typical Applications

- Hot Water Dispenser, Water Purifier
- Vending Machine
- Beverage Dispenser
- Auto Air-conditioning System
- Chiller
- Cooling Circulation System
- 3D Laser Printer Cooling
- Battery Cooling System
- Water tank Circulation of heat pump heater
- Purifying humidifier

Features

- Resistant to 100°C high temperature
- FDA, NSF, WRAS certified
- 35dB(A), super quiet
- 20,000 hours long working life
- Small size, light weight
- Intelligent control speed regulation

Specification

Model	Product Code	Rated Voltage (VDC)	Max Water Flow (L/min)	Max Water Head (M)	Rated Current (A)	Rated Power (W)	At Max Efficiency Point	
							Rated Spec. (L/min @ M)	Rated Power (W)
B10-B	B10-B12-0905	12	9	5	1.38	16.6	5.16 @ 2.86	14.3
	B10-B24-1208	24	12	8	1.3	31.2	6.89 @ 5.14	28.6
B10-C	B10-C12-0905	12	9	5	1.38	16.6	5.16 @ 2.86	14.3
	B10-C24-0905	24	9	5	0.65	15.6	5.16 @ 2.88	13.4
	B10-C24-1208	24	12	8	1.3	31.2	6.78 @ 4.81	28.6

Customization: 1. /PWM or /5V speed control 2. /FG (RPM) signal wire

- The data in the table is the measured performance when pure water is delivered at normal temperature.
- The maximum flow rate is the flow rate when water head is 0 meter, and the highest lift is the lift when water flow is 0 L/min.
- Noise ≤ 35dB(A)
- Working mode: Continuous
- IP level: Ip68
- Coil Insulation class: Class F
- Ambient temperature: -40°C ~40°C
- Liquid temperature: -40°C ~100°C (31W pump 75°C only)
- Do Not Run Pumps Dry.
- Pumps must be in a continuous flooded suction environment.

B10

Food Grade DC Pump



Curve

B10-B Performance

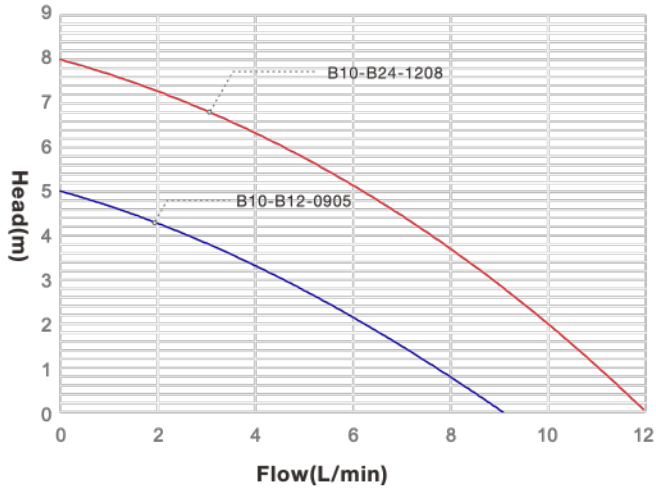

B10-C Performance

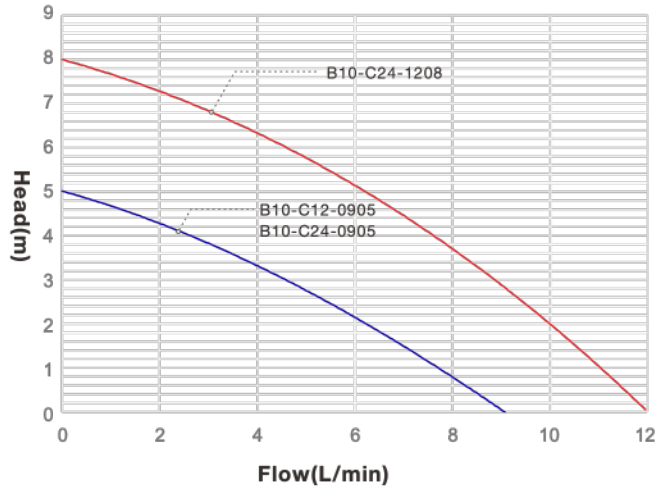

Dimension (mm)

Note: pump A / D / F lead wire pls refer to B / C type pump

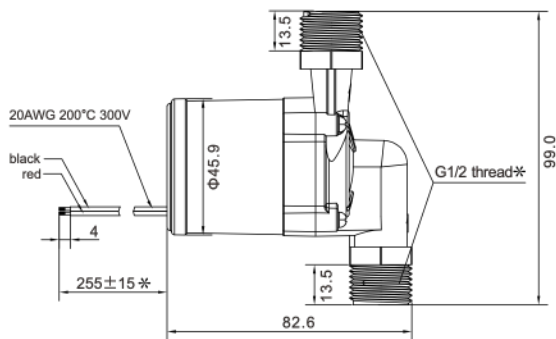

Standard Version Pump B

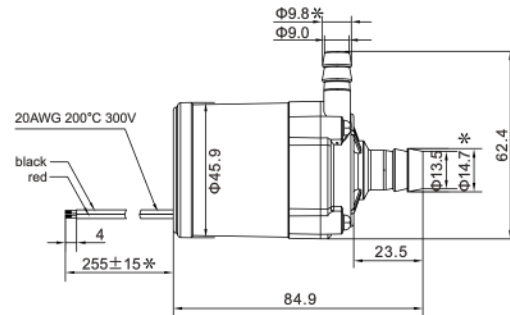

Standard Version Pump C

